

HC2D2HW miniBOOSTER



HC2D2HW versions: 4 different intensification factors

P_{IN} : 20 – 207 bar (inlet pressure)

P_H : 1,380 bar maximum (outlet pressure)

P_{RETURN} : As low as possible (return pressure to tank)

P_{OUTLET} : $P_H = (P_{IN} - P_{RETURN}) \cdot i$ (intensification)

The intensification ratio is related to the inlet pressure at media 2, the values in the table are measured at 1 bar on media 2

Drain connections: Max. 5 bar

Mounting: Inline tube

A model = no dump valve

Material certificate 3.1 on request

Description

HC2D2HW is a dual media unit which is capable of delivering up to 1.6 l/min flow on the high- pressure end. Like other miniBOOSTER models, the HC2D2HW raises supplied pressure to a higher outlet pressure and automatically compensates for consumption of oil to maintain the high pressure.

Adjustment of the outlet pressure is carried out by varying the supplied pressure. Relative to its flow capability, the HC2D2HW is a compact unit weighing 8.0 kg.

Flow rates

| Intensification factor i | Max. outlet flow l/ min | Max. inlet flow l/ min |
|-------------------------------|----------------------------|---------------------------|
| 4.0 | 1.6 | 7.0 |
| 5.6 | 1.3 | 8.0 |
| 8.0 | 1.0 | 8.0 |
| 12.0 | 0.6 | 8.0 |

Functions

The basic operation is illustrated in the function diagram. Media 1 is fed through the IN port flowing freely through the bistable valve BV1 driving the LP pistons. From the suction inlet IN Media 2 is drawn through the check valves 2 x KV1, and pumped through the 2 x KV2 to the high- pressure side H. In this condition maximum flow through the booster is achieved giving a fast- forward function.

The unit will automatically stall when end pressure on high- pressure side H is reached. If a pressure drop on the high- pressure side exists due to consumption or leakage, the HP1 and HP2 units will automatically operate to maintain the end pressure.

Function diagram

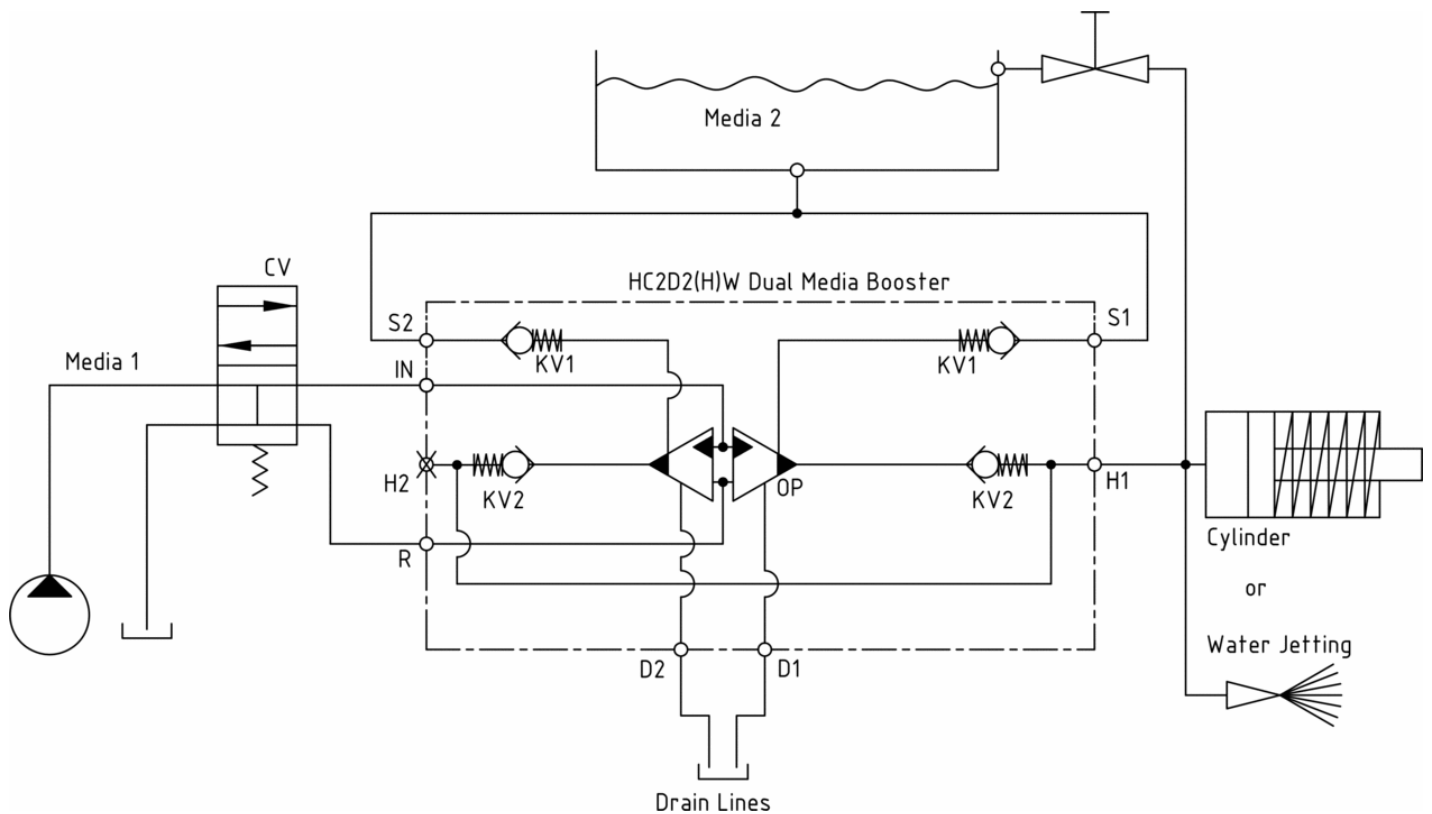

Function diagram 2D2W-105-00

Dimensions



Dimension drawing 2D2HW-120-00

Connection types

| Connection | IN / R | H1 & H2 | S1 & S2 | D1 & D2 |
|------------|-----------|-----------|-----------|-----------|
| 1 | 1/4" BSPP | M22 x 1,5 | 3/8" BSPP | 1/8" BSPP |

Max. tightening torque BSPP

| | IN / R | S1 & S2 | D1 & D2 |
|-------------------|------------|------------|------------|
| Stainless | 1/4" BSPP | 3/8" BSPP | 1/8" BSPP |
| with steel washer | 4.0 da/ Nm | 6.0 da/ Nm | 2.0 da/ Nm |
| with cutting edge | 4.0 da/ Nm | 6.0 da/ Nm | 2.0 da/ Nm |

High- pressure adapters

High- pressure adapter ordering codes and specifications are shown in the PDF- file below:



High- pressure adapters: 7W-900-06

Dynamic seals

| Code | Media 1 & 2 | Outlet pressure |
|------|-----------------|------------------|
| HH | H- PUR / H- PUR | Max 1,380 bar HP |
| HP | H- PUR / PEEK | Max 1,380 bar HP |
| EP | EPDM / PEEK | Max 1,380 bar HP |
| PP | PEEK / PEEK | Max 1,380 bar HP |

Fluids

Media 1: Recognized hydraulic fluids, glycol solutions (Min > 5%)
 Media 2: Hydraulic fluids, glycol, water, sea water



For other media, such as methanol - contact miniBOOSTER

Materials

- Body and internal components: Stainless steel 316 W.1.4404 - Material certificate 3.1 on request
- Dynamic seals, see table

Ordering an HC2D2HW

Ordering example of an HC2D2HW with $i = 4.0$, with BSPP connections, H1 and H2 M22 x 1.5 and H_PUR/ PEEK seals:

HC2D2HW - 4.0 - A - 1HP

High- pressure adapter ordering code – see table

| Model | Intensification, i | Dump valve | Connections | Dynamic seals |
|--------------|--|--------------------|--------------------|----------------------|
| HC2D2HW | your selection... | your selection... | your selection... | your selection... |
| | see flow rate table | A = (no) / A model | 1 | see seal table |